

# Projector Mount Installation Instructions

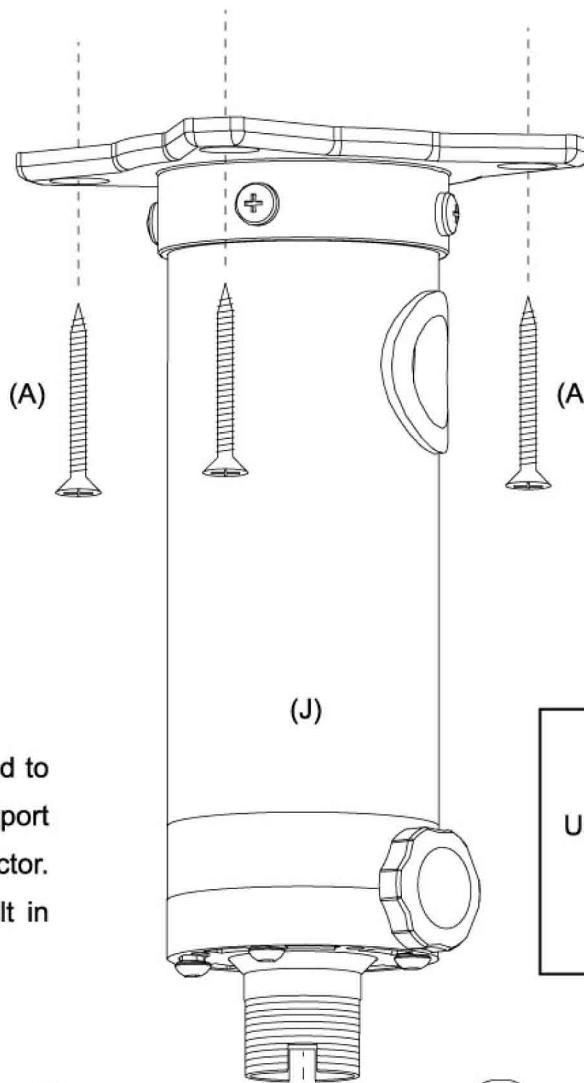
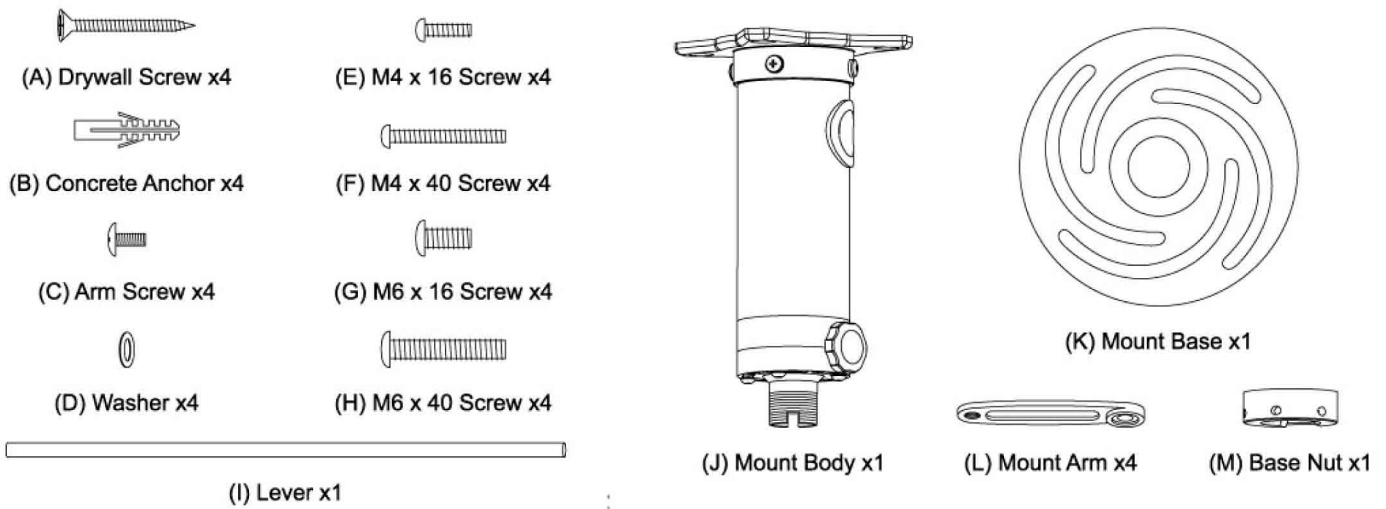

**reflecta**

## ⚠ WARNING

This mount must be attached to a ceiling joist in order to support the weight of the projector. Failure to do this may result in damage or injury.

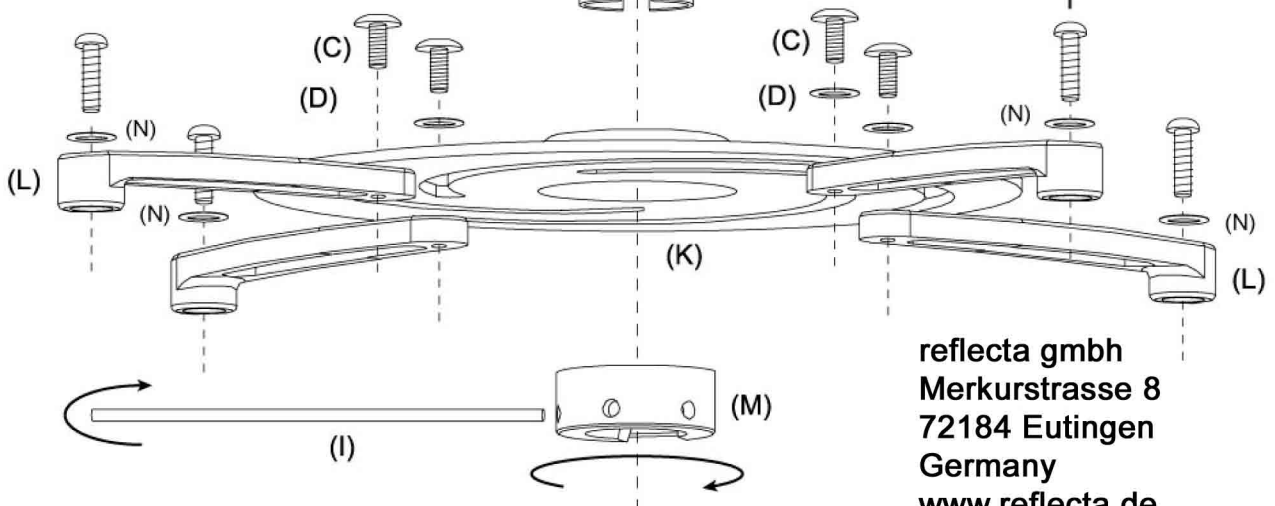
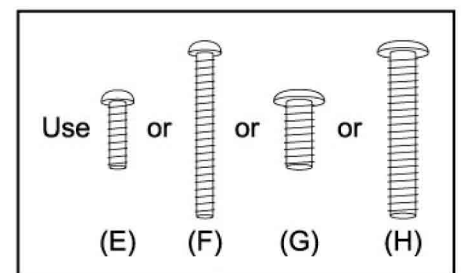

reflecta gmbh  
 Merkurstrasse 8  
 72184 Eutingen  
 Germany  
[www.reflecta.de](http://www.reflecta.de)